

Crane lifting eye optional
Article number: 911011005

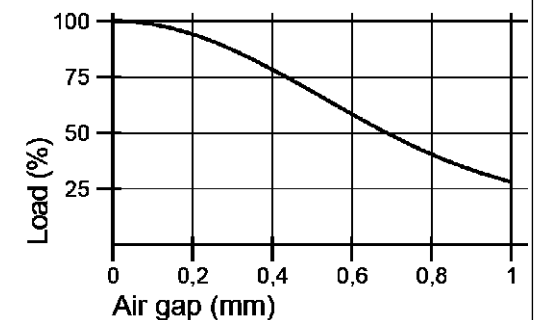
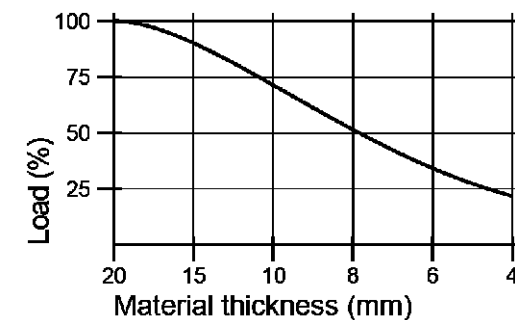
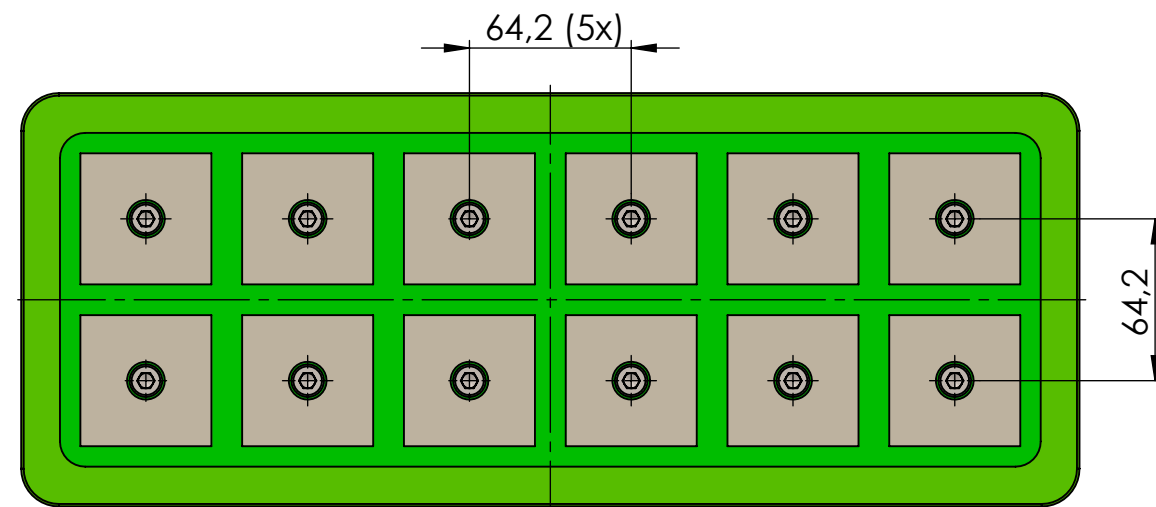
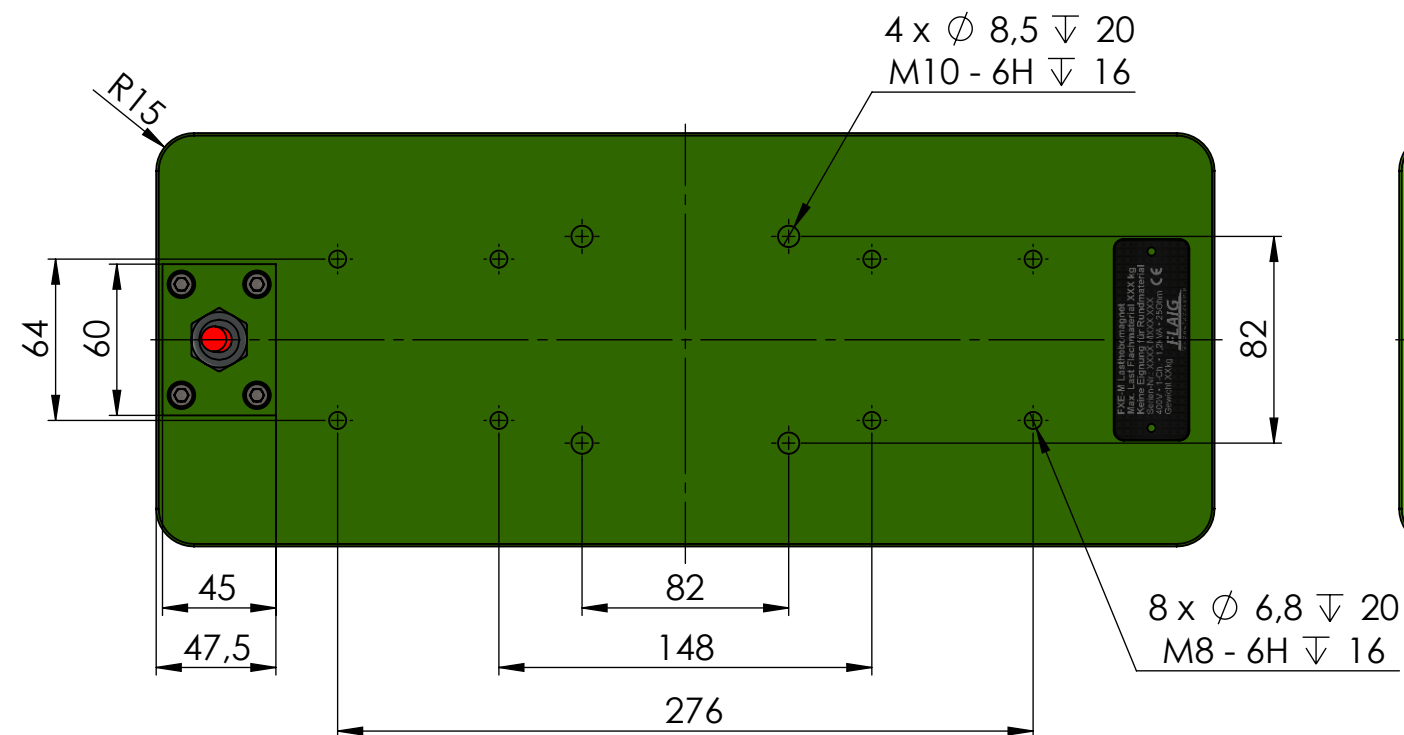
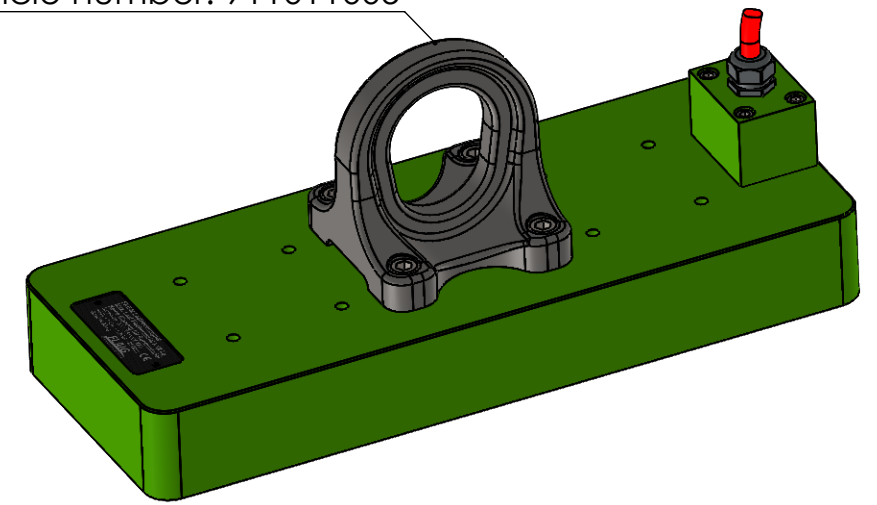

Specification FXE-M 1100-50	
Nominative Force: 45,6kN	lifting capacity EN 13155/WLL
Materialthickness >15mm (100%)	1100kg
3,5kVA	
U: 380-480V Pulse	Protection Type IP 65
R: 7,8Ω	Protection category SK I

Schutzvermerk nach DIN ISO 16016 beachten! Nachdruck nur mit unserer Genehmigung!		3,2 / -0,05 / -0,2	tolerance	material:	weight: 28.20
All rights reserved according to DIN ISO 16016! Reprint with our permission only!			ISO 7168 M	drawing no.:	0012963
date	name				
drawn 15.02.2021	MF				
edit 30.05.2022					
appr. 30.05.2022	TW	description: FXE M 1100-50		part no.: 10611101	
rev. change date name		www.flraig-te.de		sheet 1 / 1	A3
		scale: 1:3		Status: Freigegeben	